

SUBSTRUCTURE PLAN
REINFORCEMENT
SCALE: 1:75

NOTE: VERTICAL REINFORCEMENT NOT SHOWN FOR CLARITY

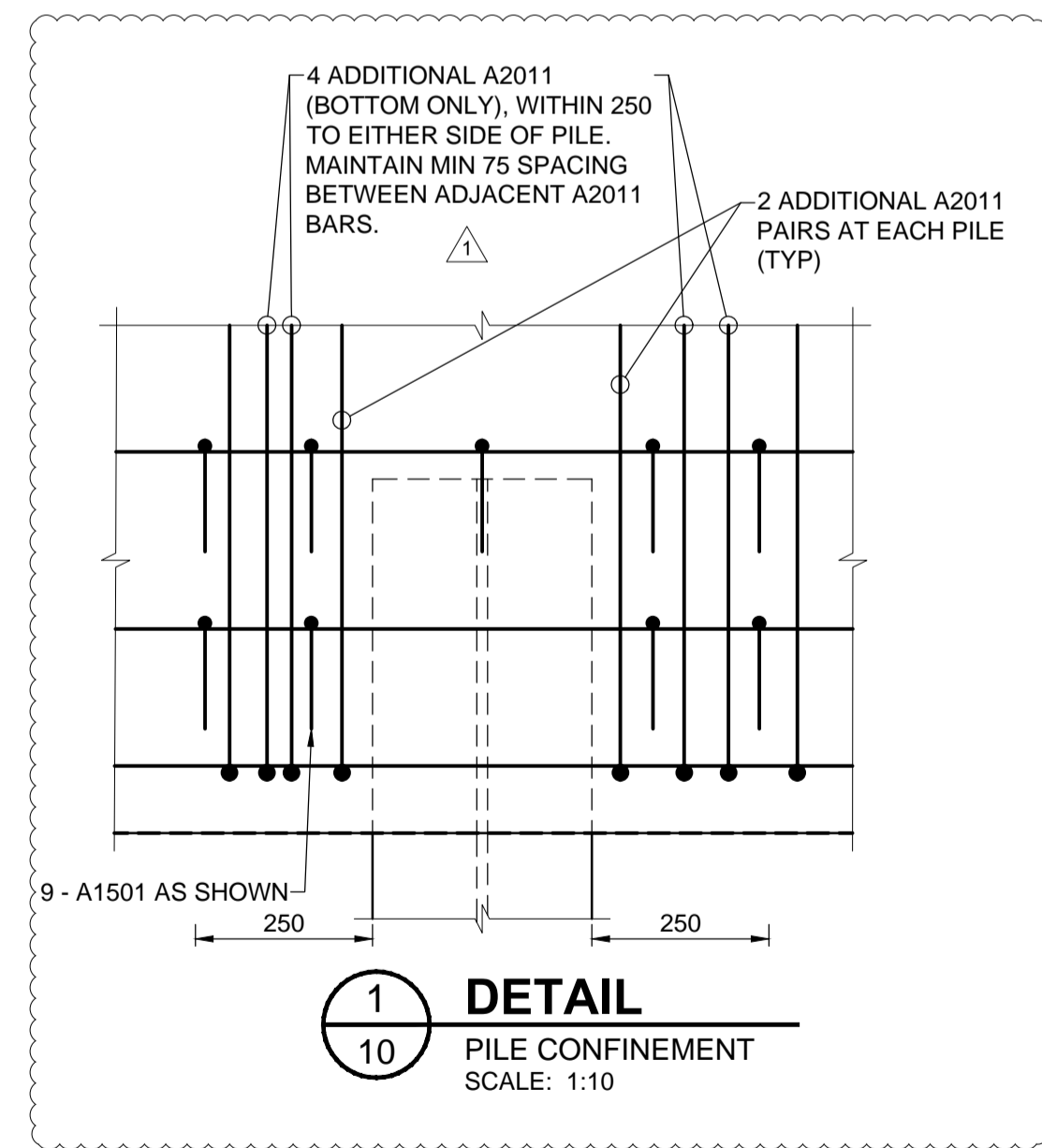

DETAIL
PILE CONFINEMENT
SCALE: 1:10

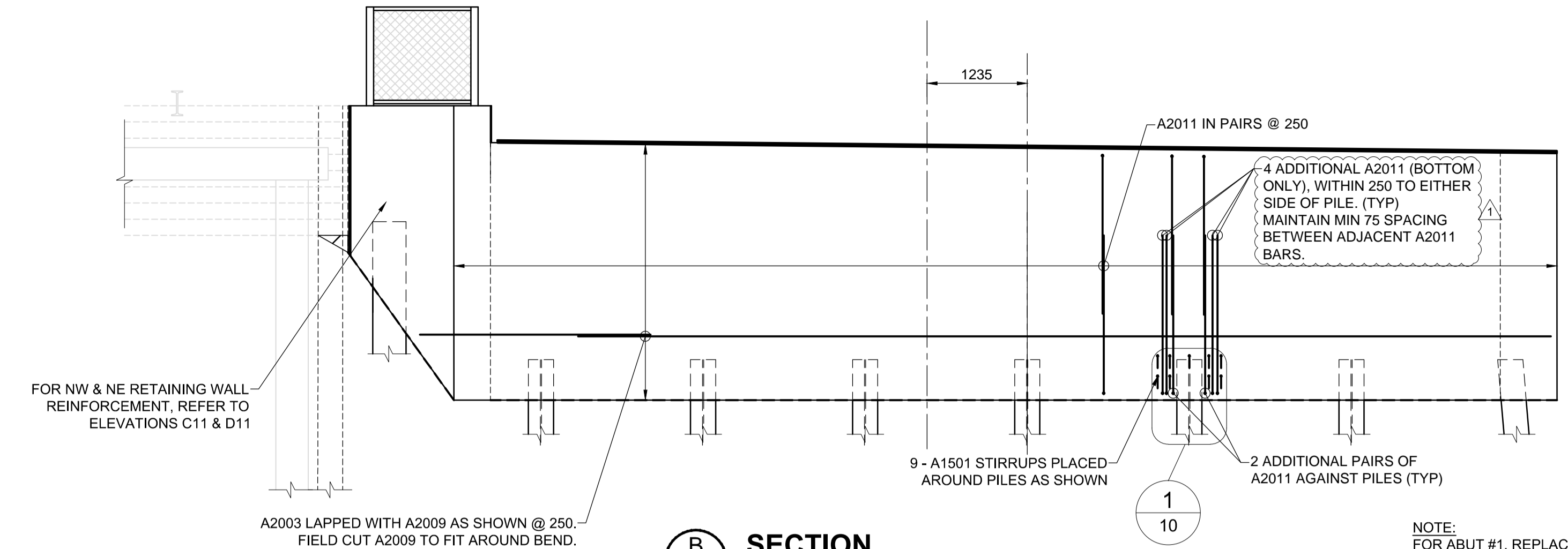

B SECTION
10 ABUT #2 SHOWN, ABUT #1 SIMILAR WHEN MIRRORED - REINFORCEMENT
SCALE: 1:50

NOTE:
FOR ABUT #1, REPLACE
A2009 WITH A2008

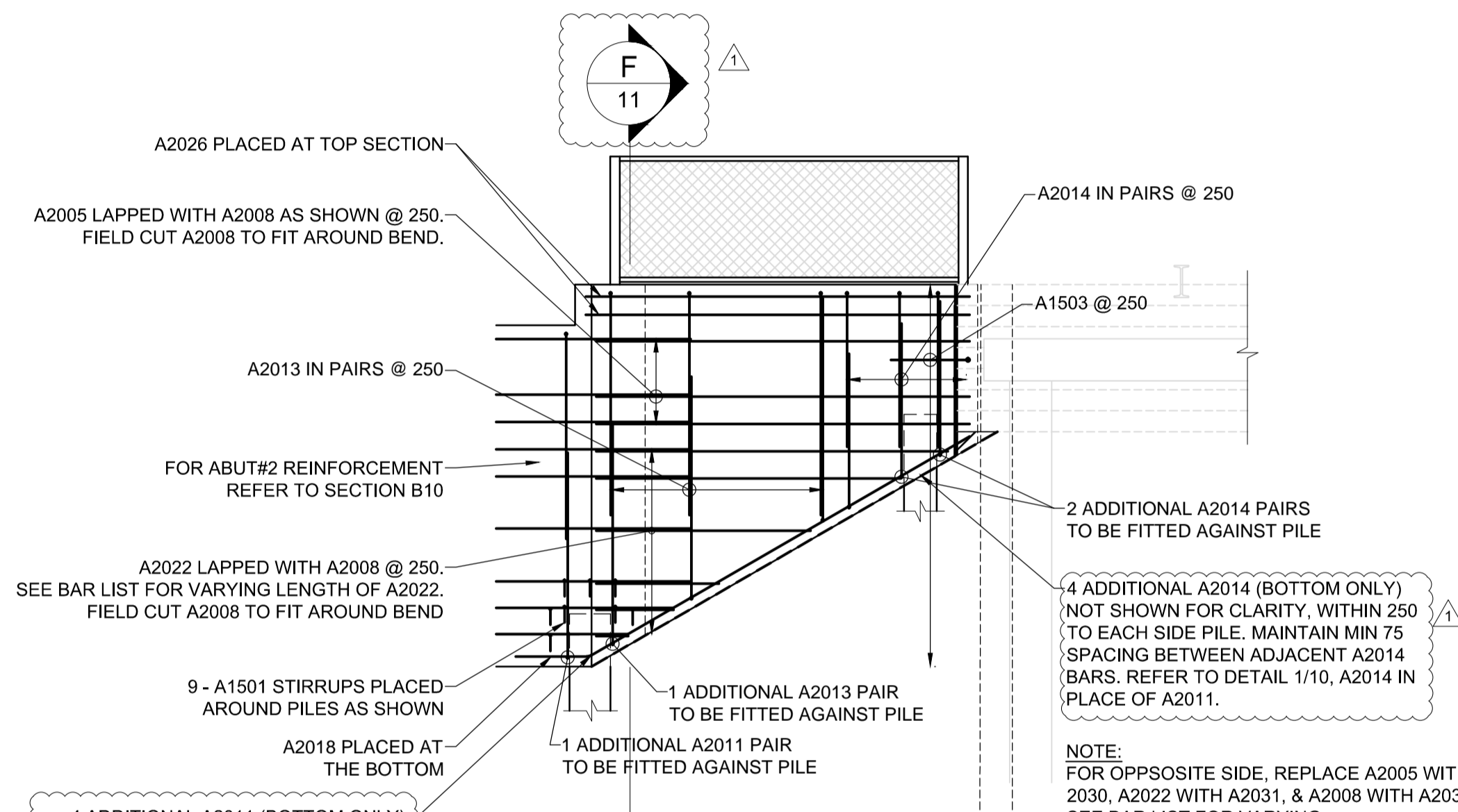

C ELEVATION
10 NW RETAINING WALL - REINFORCEMENT
SCALE: 1:50

NOTE:
FOR OPPOSITE SIDE, REPLACE
A2005 WITH A
2030, A2022 WITH A2031, & A2008 WITH A2032
SEE BAR LIST FOR VARYING
LENGTH OF A2031

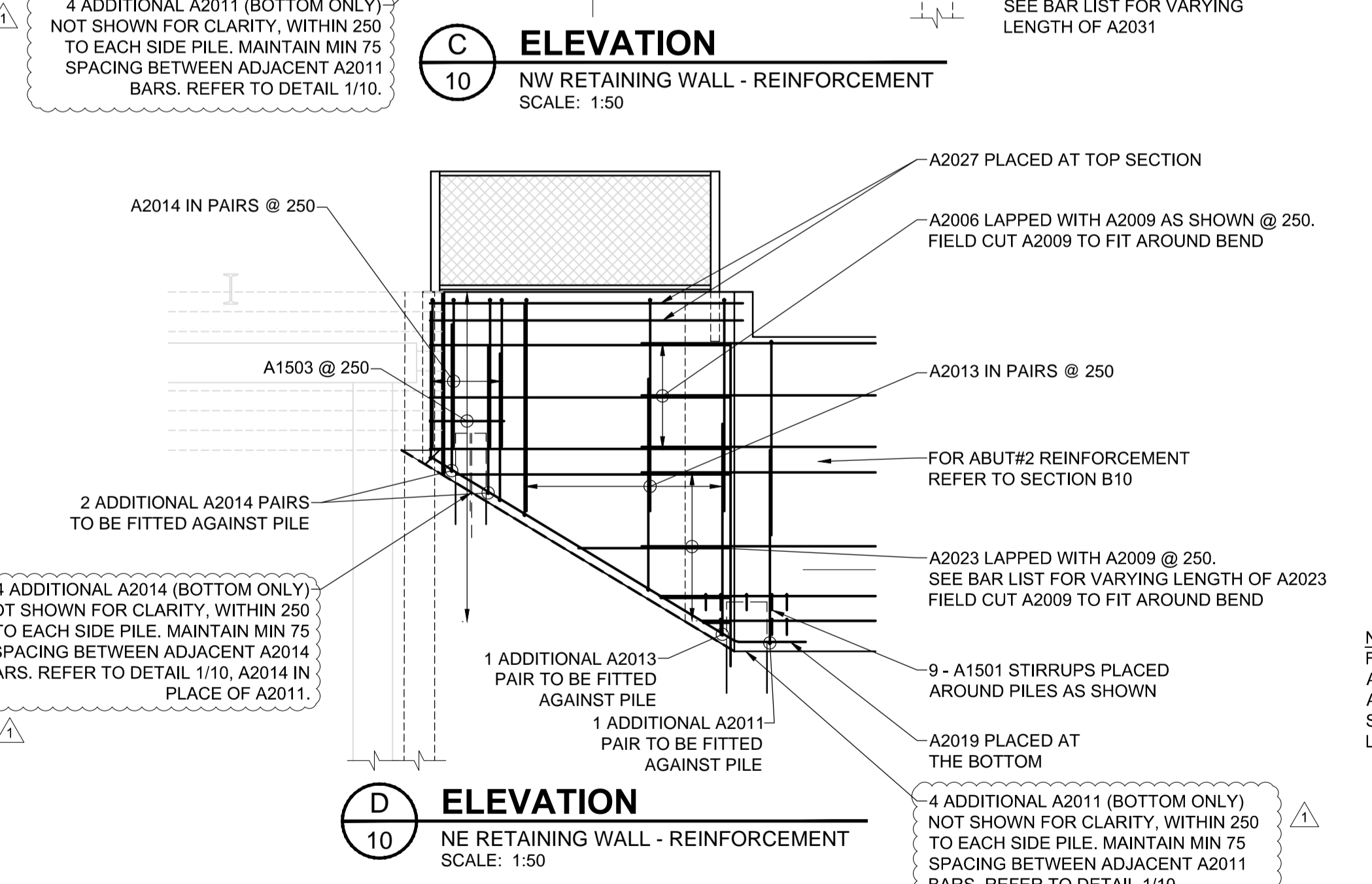

D ELEVATION
10 NE RETAINING WALL - REINFORCEMENT
SCALE: 1:50

NOTE:
FOR OPPOSITE SIDE, REPLACE
A2006 WITH A 2033, A2023 WITH
A2034, & A2009 WITH A2035
SEE BAR LIST FOR VARYING
LENGTH OF A2034

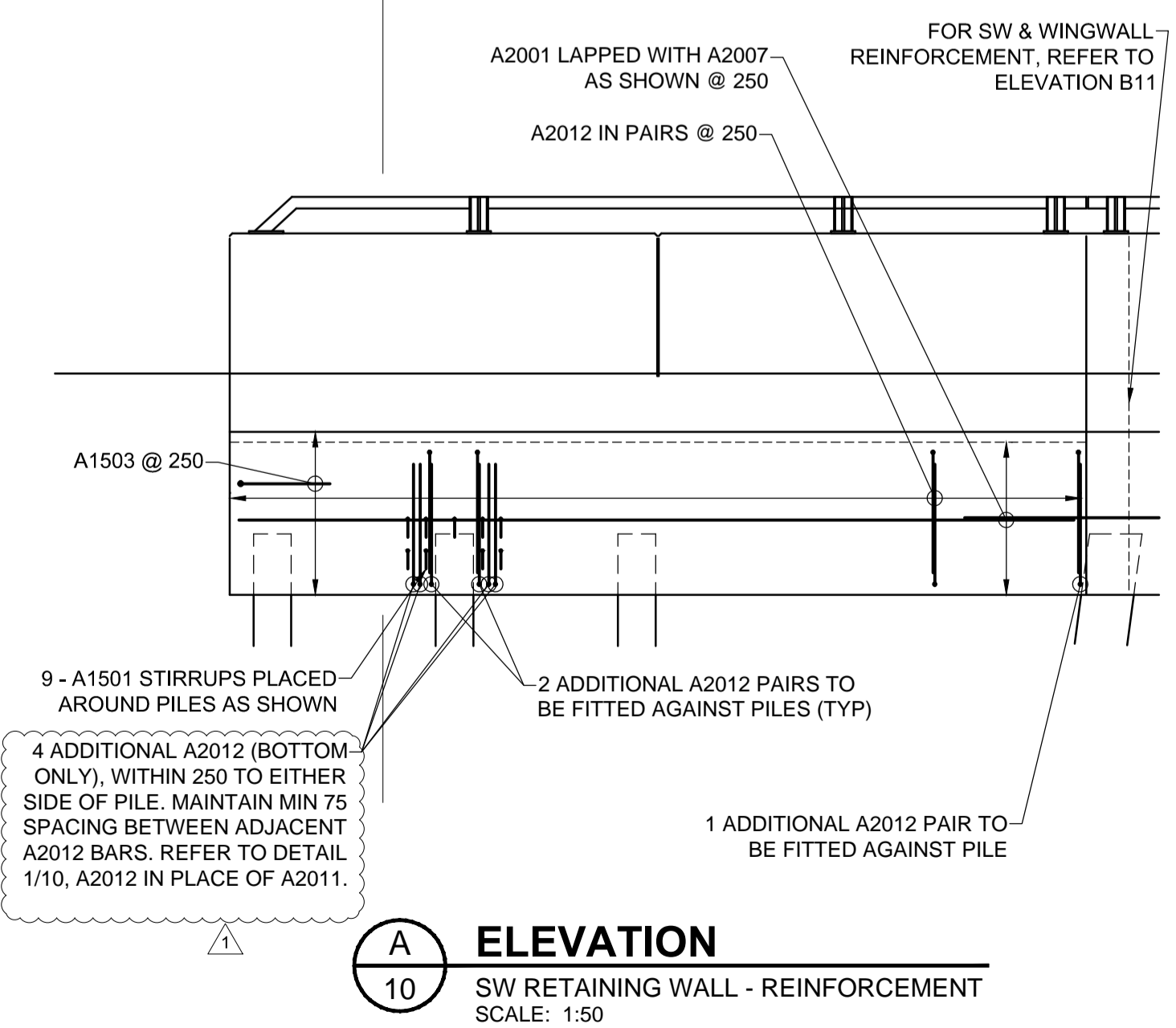

A ELEVATION
10 SW RETAINING WALL - REINFORCEMENT
SCALE: 1:50

4 ADDITIONAL A2012 (BOTTOM ONLY), WITHIN 250 TO EITHER SIDE OF PILE. MAINTAIN MIN 75 SPACING BETWEEN ADJACENT A2012 BARS. REFER TO DETAIL 1/10, A2012 IN PLACE OF A2011.

SUBSTRUCTURE REINFORCING NOTES:
REFER TO SHEETS 08 AND 09 FOR SUBSTRUCTURE GEOMETRY.

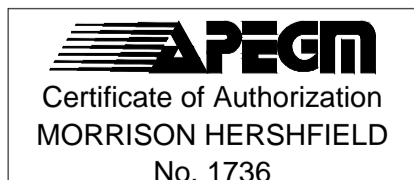

METRIC
WHOLE NUMBERS INDICATE MILLIMETRES
DECIMALIZED NUMBERS INDICATE METRES

LOCATION APPROVED UNDERGROUND STRUCTURES

SUPR. U/G STRUCTURES COMMITTEE	DATE
NOTE: LOCATION OF UNDERGROUND STRUCTURES AS SHOWN ARE BASED ON THE BEST INFORMATION AVAILABLE BUT NO GUARANTEE IS GIVEN THAT ALL EXISTING UTILITIES ARE SHOWN OR THAT THE GIVEN LOCATIONS ARE EXACT. CONFIRMATION OF EXISTENCE AND EXACT LOCATION OF ALL SERVICES MUST BE OBTAINED FROM THE INDIVIDUAL UTILITIES BEFORE PROCEEDING WITH CONSTRUCTION.	

ISSUED FOR ADDENDUM 1	15/11/10	DAN
ISSUED FOR TENDER	15/10/22	DAN
REVISIONS	YYMMDD	BY

DESIGNED BY	DAN	CHECKED BY	SAL
DRAWN BY	DML	APPROVED BY	BE
HOR. SCALE	AS SHOWN	ACCEPTED BY	DATE
VERT. SCALE	AS SHOWN	SIGNED BY	15/10/22
DATE	15/04/24	D.N. BURMEY, P.ENG.	BRIDGE PROJECTS ENGINEER



THE CITY OF WINNIPEG
PUBLIC WORKS DEPARTMENT
ENGINEERING DIVISION

SASKATCHEWAN AVENUE AT OMAND'S CREEK BRIDGE REPLACEMENT

SUBSTRUCTURE III

CITY DRAWING NUMBER: B144-16-10
SHEET 10 OF 18
DRAWING No. 10
REV 1